



MAX4147 Evaluation Kit

General Description

The MAX4147 evaluation kit (EV kit) simplifies evaluation of the MAX4147 high-speed, high-output-current, differential line driver. The EV kit circuit demonstrates the MAX4147 ($A_V = 2V/V$).

This EV kit may also be used to evaluate the MAX4142. Contact the factory to order a free sample.

Ordering Information

PART	TEMP. RANGE	BOARD TYPE
MAX4147EVKIT-SO	+25°C	Surface Mount

Note: To evaluate the MAX4142, request a MAX4142ESD free sample.

Component List

DESIGNATION	QTY	DESCRIPTION
C1–C4	4	0.1 μ F, 10% ceramic capacitors Vitramon VJ1206Y104KXX
C5, C6	2	10 μ F, 10V, 20% tantalum capacitors AVX TAJB106M010 Sprague 293D106X0010B
IN+, IN-, OUT+, OUT-	4	SMA connectors
R1–R4	4	49.9 Ω , 1% resistors
U1	1	MAX4147ESD
None	1	MAX4147 PC board
None	1	MAX4147 data sheet
JU1	1	3-pin header
None	1	Shunt for JU1

Component Suppliers

SUPPLIER	PHONE	FAX
AVX	(803) 946-0690	(803) 626-3123
Sprague	(603) 224-1961	(603) 224-1430
Vishay/Vitramon	(203) 268-6261	(203) 452-5670

Features

- ◆ 300MHz Bandwidth
- ◆ 2000V/ μ s Slew Rate
- ◆ Fully Assembled and Tested

Quick Start

The MAX4147 EV kit is fully assembled and tested. Follow these steps to verify board operation. **Do not turn on the power supply until all connections are completed.**

- 1) Connect a +5V supply to the pad marked VCC. Connect a -5V supply to the pad marked VEE. Connect the power-supply ground to the pad marked GND.
- 2) Verify that there is a shunt across pins 1 and 2 of jumper JU1.
- 3) Apply signals to IN+ and IN-, whose differential voltage does not exceed 2.5V. These signals must not exceed the amplifier's input common-mode range of $\pm 2.8V$.
- 4) Connect the output marked OUT+ or OUT- to an oscilloscope through a terminated 50 Ω cable.
- 5) Turn on the power supply and verify the output signal on the oscilloscope.

Detailed Description

Shutdown Control

The MAX4147 provides a SHDN pin to disable the output. Table 1 lists the options available for the shutdown-control jumper, JU1. To use an external controller, remove the shunt on JU1 completely and connect the external controller to the pad labeled SHDN. SHDN is a TTL/CMOS logic-level input.

Table 1. Jumper JU1 Functions

SHUNT LOCATION	SHDN PIN	MAX4147 OUTPUT
1 & 2	Connected to GND	MAX4147 enabled
2 & 3	Connected to VCC	Shutdown mode

Evaluates: MAX4142/MAX4147

MAX4147 Evaluation Kit

Layout Considerations

The MAX4147 EV kit layout has been optimized for high-speed signals and low distortion, with careful attention given to grounding, power-supply bypassing, and signal-path layout. The small, surface-mount, ceramic bypass capacitors (C1, C2, C3, and C4) have

been placed as close to the four MAX4147 supply pins as possible. The ground plane has been removed around and under the MAX4147 to reduce stray capacitance. The removal of ground plane around the input SMA connectors reduces distortion.

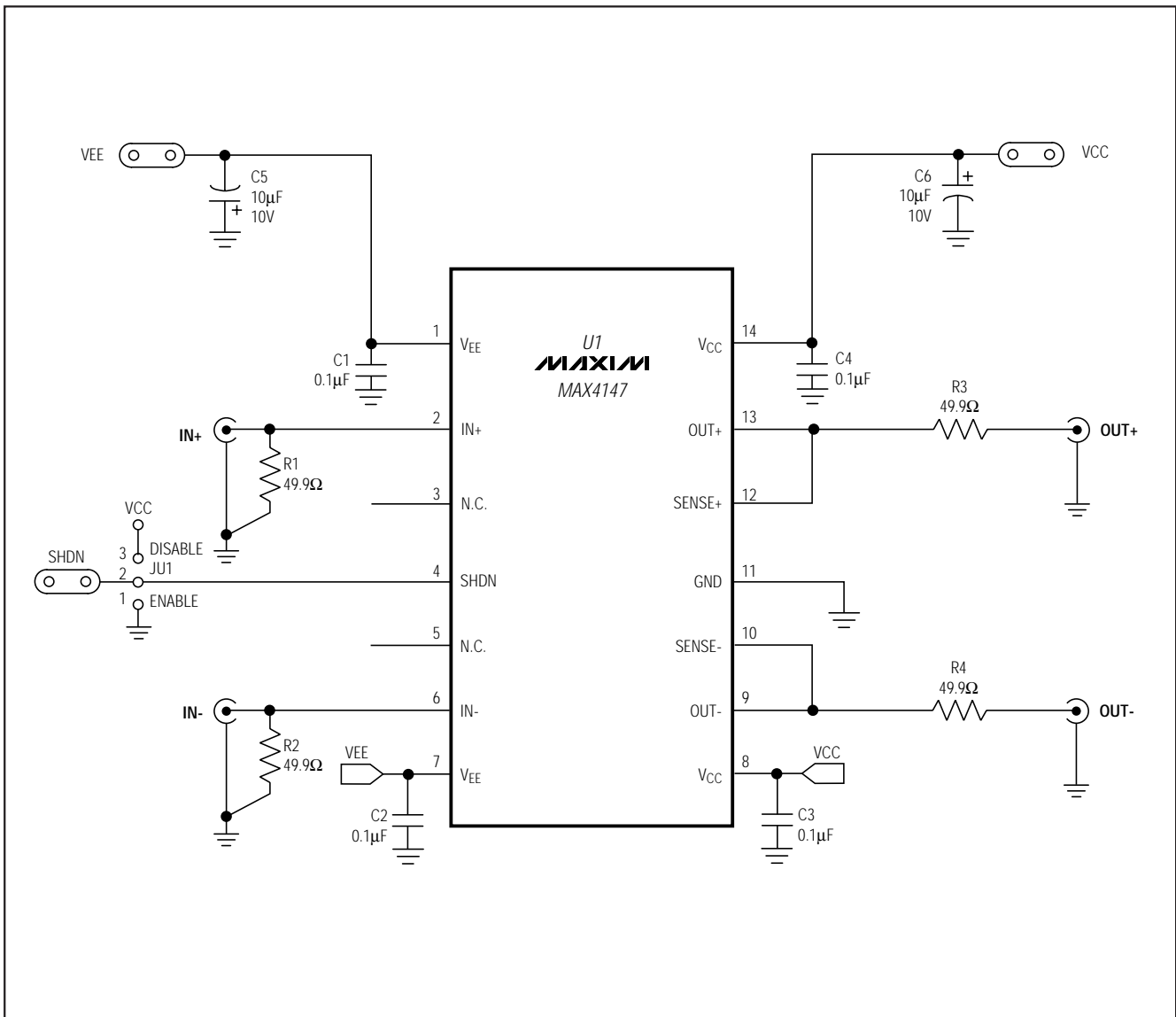

Figure 1. MAX4147 EV Kit Schematic

MAX4147 Evaluation Kit

Evaluates: MAX4142/MAX4147

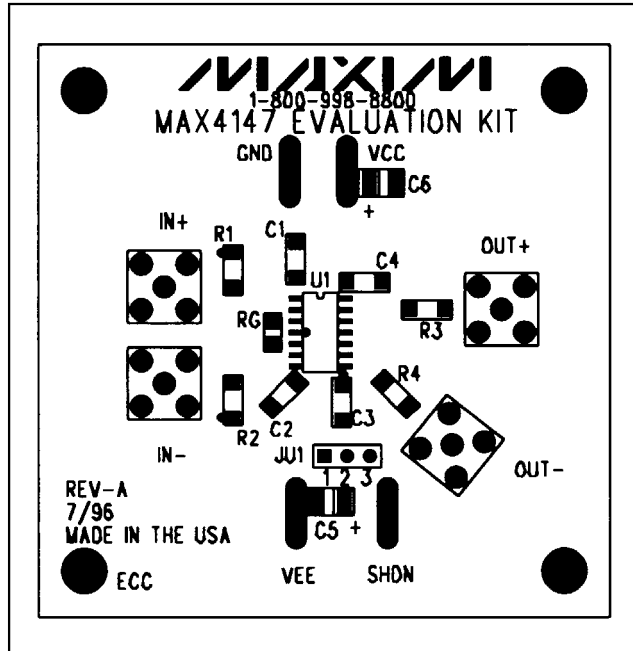

Figure 2. MAX4147 EV Kit Component Placement Guide—Component Side

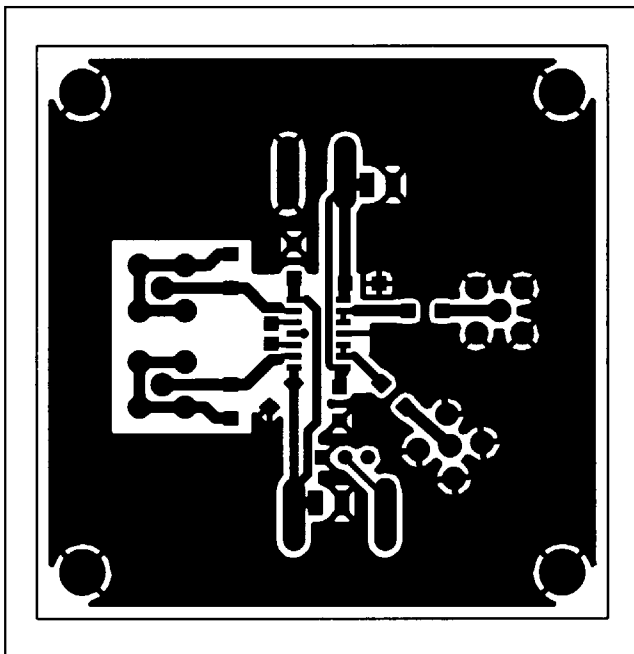

Figure 3. MAX4147 EV Kit PC Board Layout—Component Side

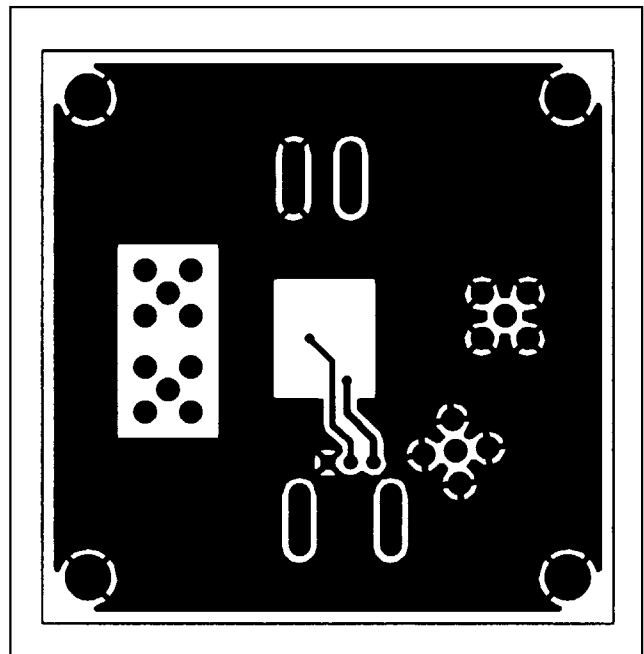

Figure 4. MAX4147 EV Kit PC Board Layout—Solder Side

MAX4147 Evaluation Kit

Evaluates: MAX4142/MAX4147

NOTES

Maxim cannot assume responsibility for use of any circuitry other than circuitry entirely embodied in a Maxim product. No circuit patent licenses are implied. Maxim reserves the right to change the circuitry and specifications without notice at any time.

4 _____ Maxim Integrated Products, 120 San Gabriel Drive, Sunnyvale, CA 94086 408-737-7600

© 1998 Maxim Integrated Products

Printed USA

MAXIM is a registered trademark of Maxim Integrated Products.